

Turntable Road-Marking Test System (RPA)



The turntable road-marking test system of the Federal Highway Research Institute (BAST)
(Photo: Uwe Freier)

Seeing and being seen are important preconditions for safety on the road. The latter particularly applies to road markings which can be considered as an essential element of visual guidance for the road user. Motorists (including motorcyclists), in particular, must be able to trust these road markings, both in the daytime and at night – and particularly in wet conditions.

To ensure that road markings meet the requirements with regard to safety as well as durability, the Federal Highway Research Institute (BAST) has been conducting approval tests since 1957 on behalf of today's Federal Ministry of Transport and Digital Infrastructure (BMVI). The suitability tests were initially carried out according to national regulations and – since 2000 – according to European standards.

Until the middle of the 1980s, road markings were tested only on test beds in real traffic conditions. These test beds, however, suffered from the critical disadvantage that results

only became available after the actual test period. Moreover, it also proved necessary to close off roads and divert traffic when applying the markings and conducting the periodic measurements. This, in turn, led to traffic conflicts and great danger to the personnel involved in carrying out the work. Such a procedure is no longer conceivable in view of the traffic density prevailing on the roads in Germany today.

The road in the laboratory

In order to continue with the approval tests, the BAST developed a test method, which is less complex and more informative under the same boundary conditions than was possible with the test beds due to the imponderable factors involved in the latter case. The turntable road-marking test system (RPA) has enabled the road to be brought into the laboratory. This is a special facility, at which suitability tests were conducted for the first time in 1989

after many years of development and trials.

The system

The RPA essentially consists of a horizontally arranged turntable with a diameter of 6.40 m, on which up to 20 different road markings can be tested at the same time. The road markings are loaded with up to eight test wheels, which produce the same degree of wear as real vehicles in traffic.

The testing

The road markings are applied on special test specimens, whose composition and surface correspond to a finely structured road surface consisting of mastic asphalt.

Road markings are produced from various materials, which are combined with different drop-on materials (reflective beads and anti-skid aggregates) for the purpose of ensuring visibility (also at night) as well as a sufficient grip. The combination of road-marking material and drop-on material is known as a road marking system. The road marking materials most commonly used today are:

- paints,
- reactive (cold plastic) materials,
- thermoplastic materials, and
- foils.

The test duration depends on the subsequent use intended for the respective road marking system. In this manner, road marking systems for short-term, temporary use are subject to only 100,000 wheel roll-over cycles and marking systems for permanent use up to 4 million wheel roll-over cycles. On average, some 150 different road marking systems can be tested each year. The reasons for this include the time-lapse effect, resulting from the fact that the

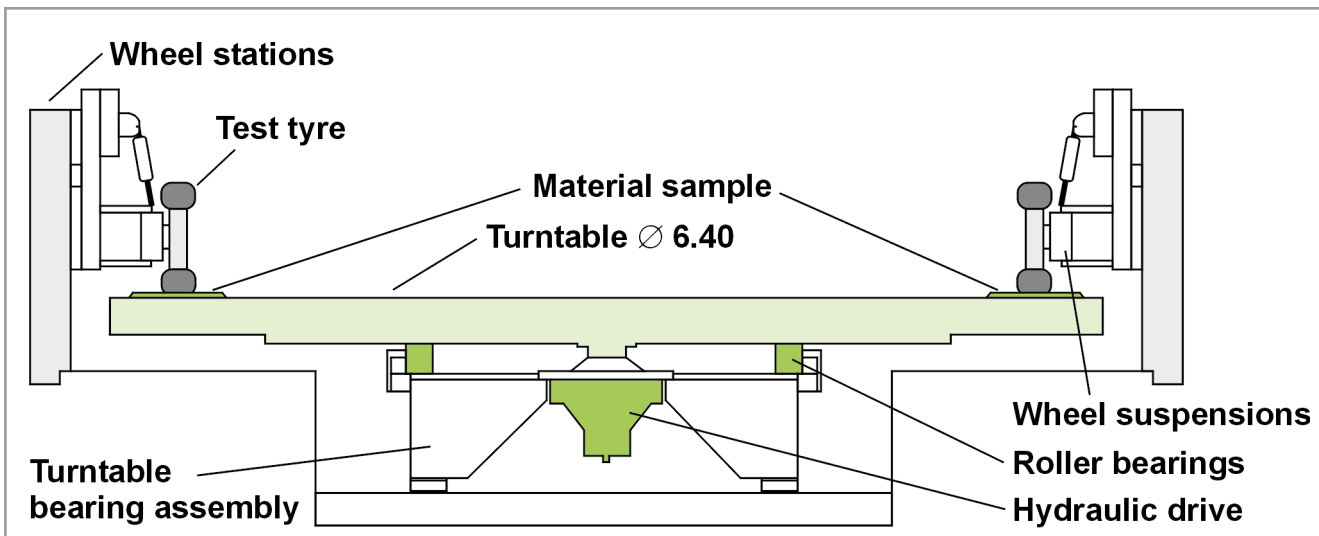

Sketch showing basic mode of the operation of the turntable road-marking test system

required number of wheel roll-overs is achieved significantly faster on the RPA than in real traffic. If the result of the test is positive, i.e., if all minimum requirements prescribed with regard to traffic-engineering characteristics and chemical-physical properties of the materials are met, the Federal Highway Research Institute issues a test certificate for the road marking system. These traffic-engineering characteristics are:

- night-time visibility in dry and wet conditions,
- day-time visibility,
- grip, and
- remaining surface

Results

The test certificates issued by the BAST form the basis for tenders and contracts when road marking work is awarded by the road administration departments of the federal states responsible for federal highways.

In addition to marking systems, other elements, generally intended for temporary use, but also partly for permanent use, such as signals, are also tested.

The high performance of the RPA has led to the road marking industry becoming extremely active in recent years. The industry uses the

capabilities provided by the RPA far more frequently than was the case with conventional test beds. A wide range of road marking systems has been tested to date and the range of products has been consequently substantially expanded.

The environment has also benefited from the turntable road-marking testing system. For example, only low-solvent paints and – to an increasing extent water-soluble materials – are used for road marking today. Heavy metals no longer have to be used for yellow marking materials.

The knowledge gained from the suitability tests using the RPA,

which are continually compared with the results from practice, are incorporated into national and international regulations, and thus serve to improve road safety.

Published by

Federal Highway Research Institute (BAST)
 Press and Public Relations
 Special consultant: Maike Zedler
 Brüderstraße 53
 D-51427 Bergisch Gladbach
 Telephone +49 2204 43-0
 E-Mail: info@bast.de
 www.bast.de
 December 2017

Technical data

Air-conditioned measuring laboratory:	8 m x 14 m
Air-conditioned testing chamber:	7.50 m x 8.50 m
Diameter of turntable:	6.40 m
Weight of turntable:	ca. 15 t
Testing speed:	0 km/h up to 120 km/h continuously adjustable
Drive:	Electro-hydraulic, 75 kW
Number of test wheels:	4 or 8
Wheel load:	3,000 N
Testing temperature:	from - 10 °C to 50 °C continuously adjustable
Relative humidity:	from 40% to 90% continuously adjustable
Air-conditioning:	2 air-conditioning systems to be used alternatively, each with 45 kW output and air throughput of 12,000 m ³ /h